

ABMESSUNGEN - DIMENSIONS

Eingabe der TANKABMESSUNGEN
OCIO verlangt, dass je nach Tanktyp 2 oder 3 Abmessungen eingegeben werden...

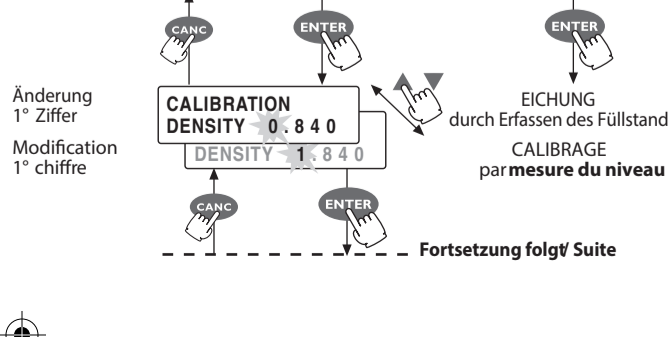

Fortsetzung folgt/ Suite

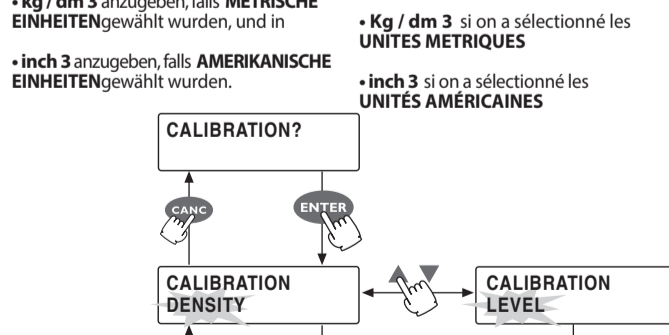
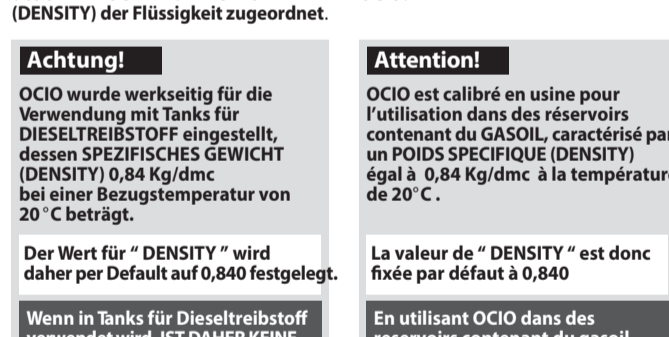
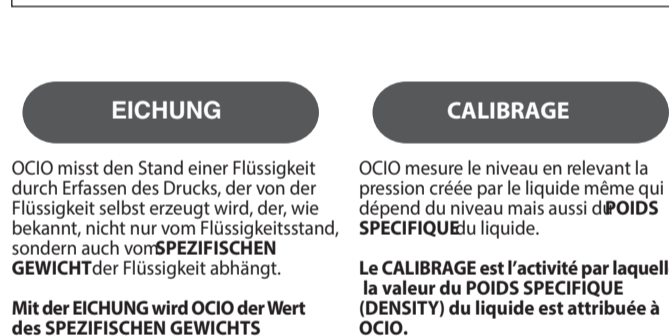
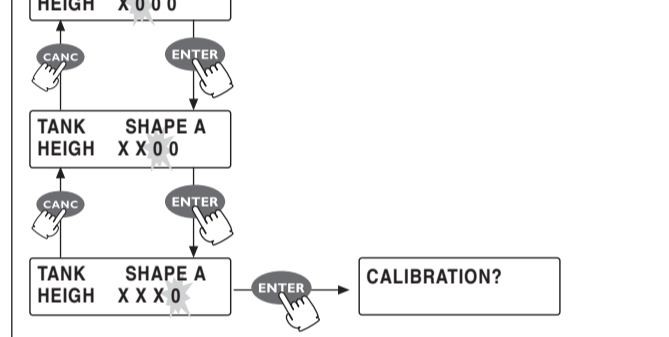
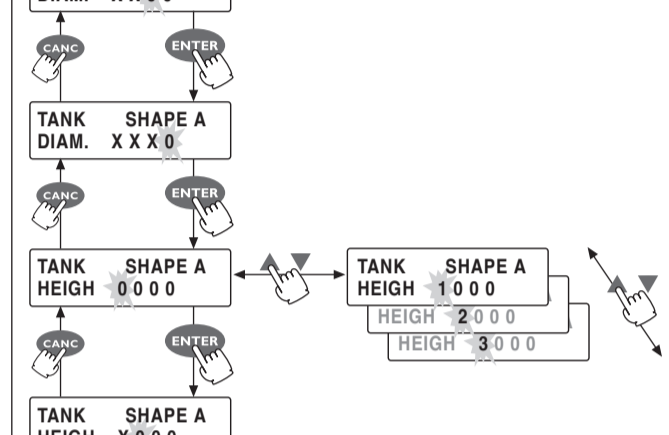
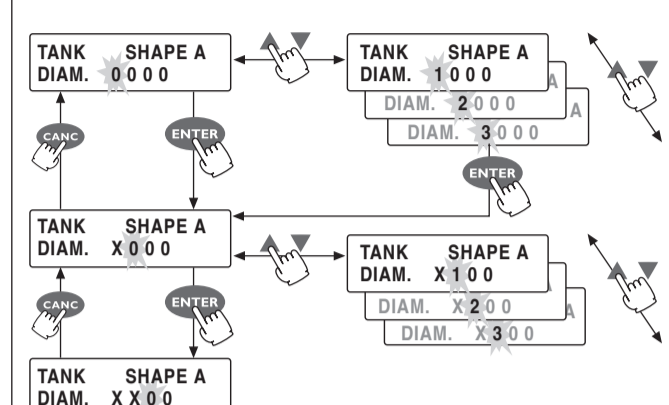
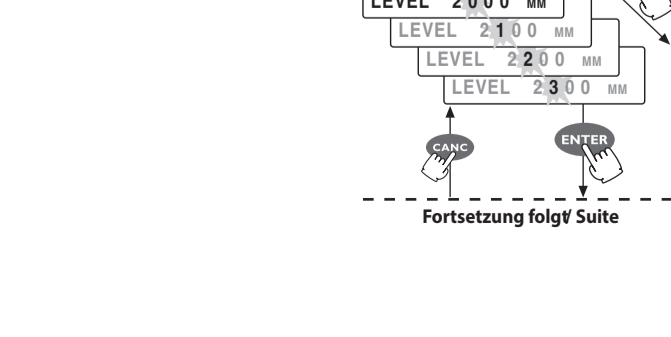
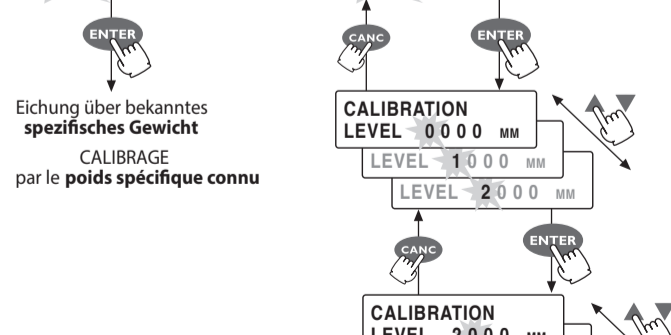
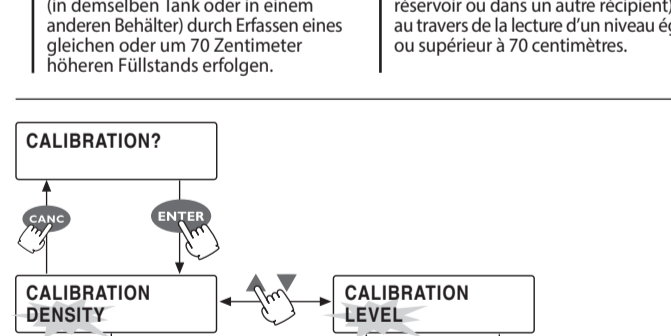
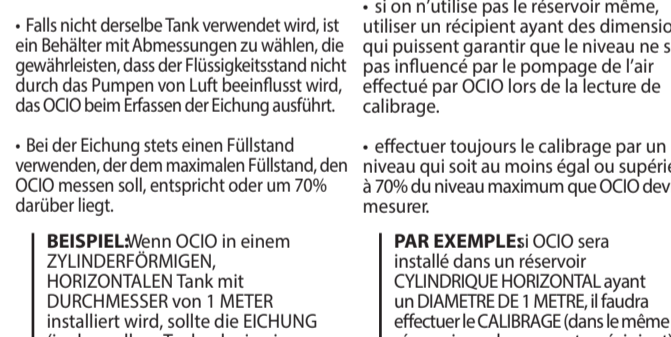
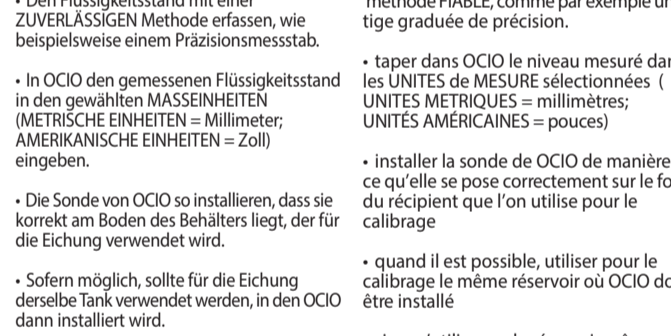
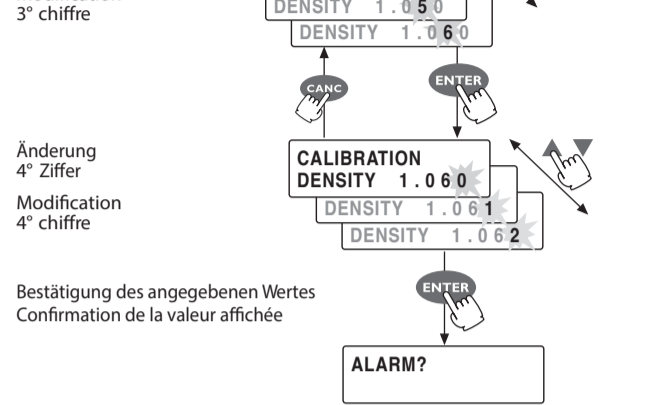
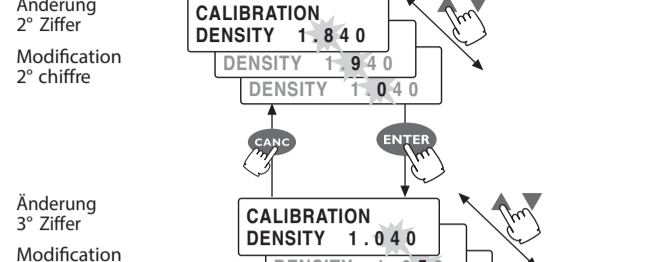

Fortsetzung folgt/ Suite

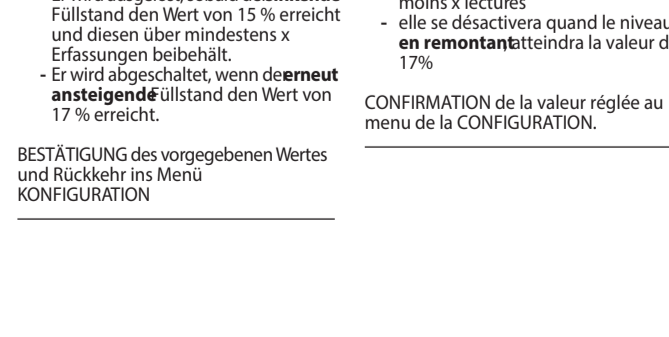
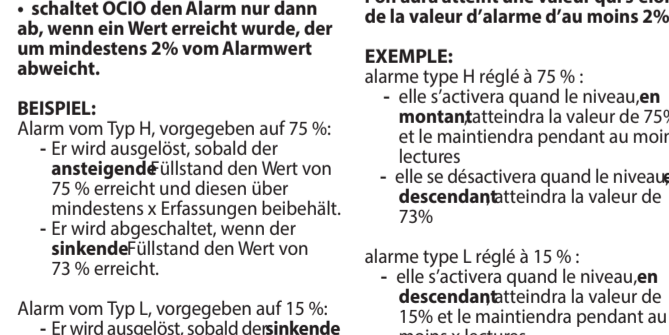
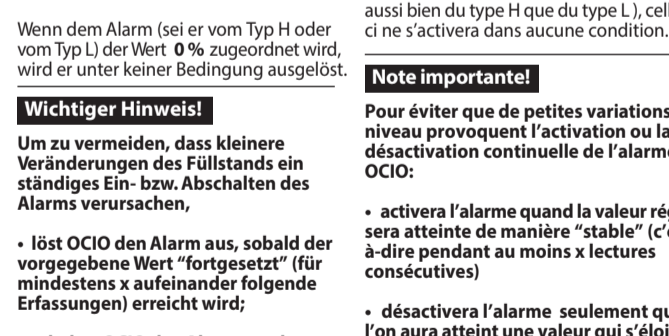
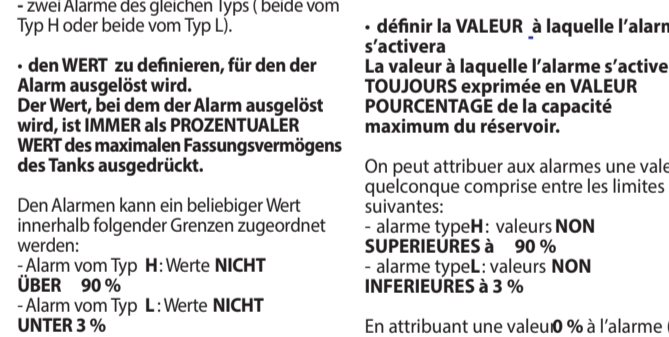
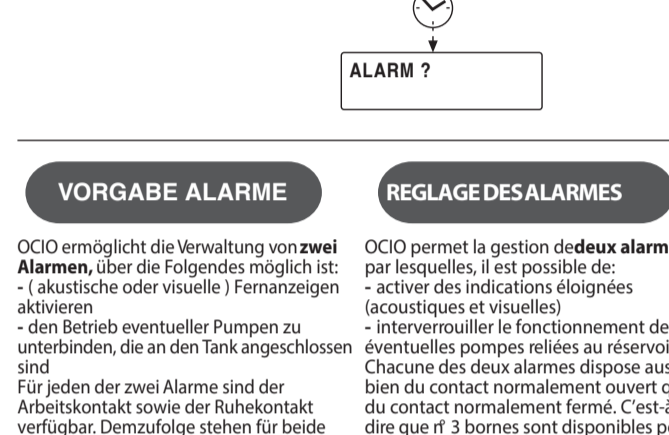
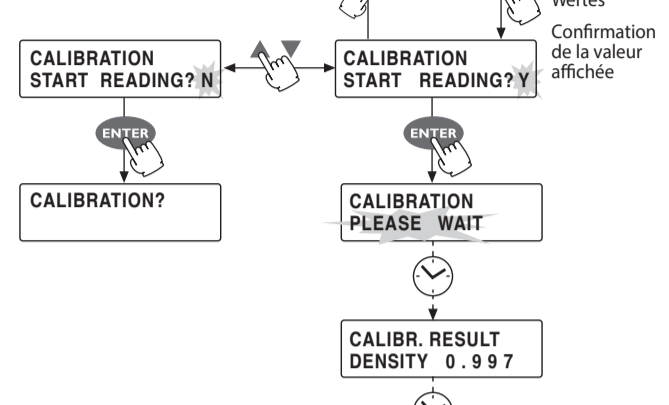
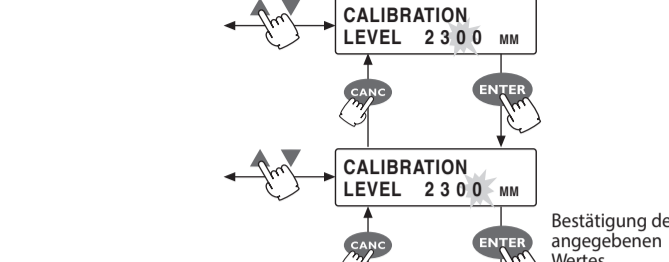

7. Täglicher Einsatz / 7. Utilisation quotidienne

Der tägliche Einsatz von OCIO ist extrem einfach und intuitiv.
Anzeige des FÜLLSTANDS ANDS oder des VOLUMENS

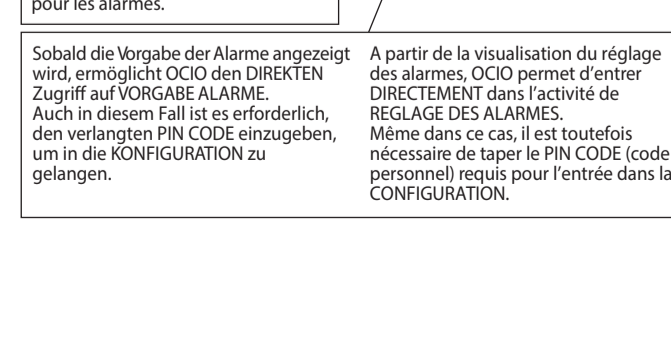
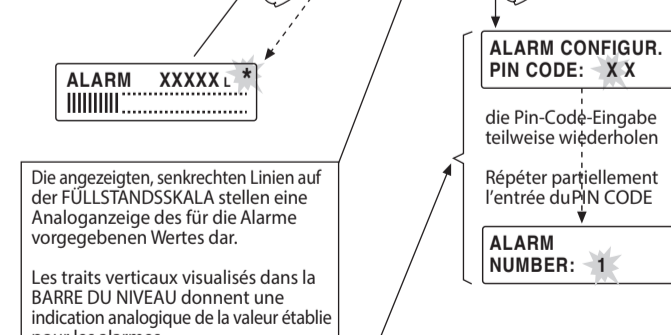
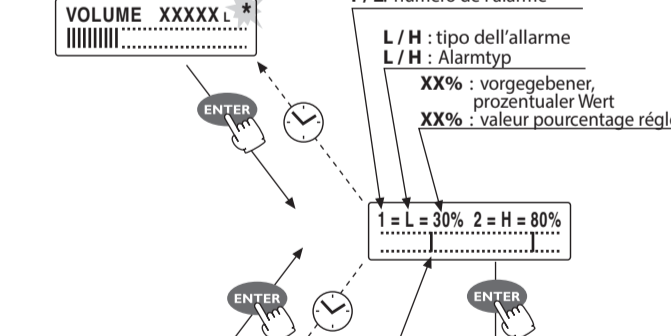
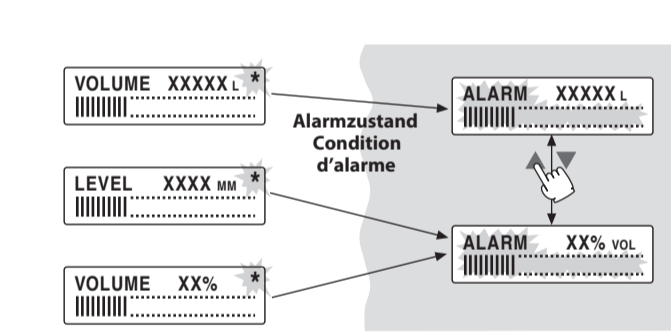
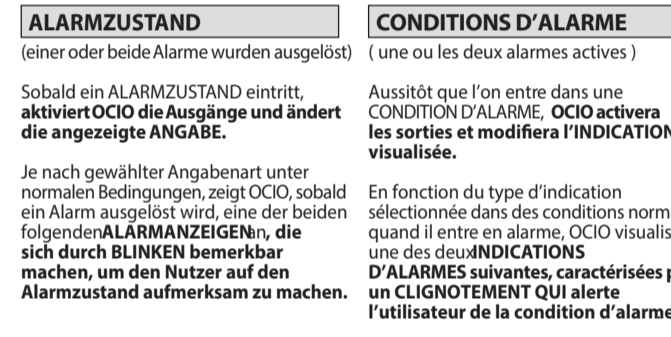
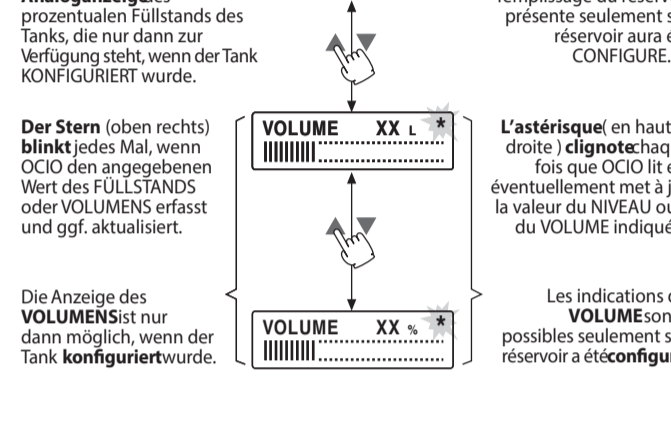
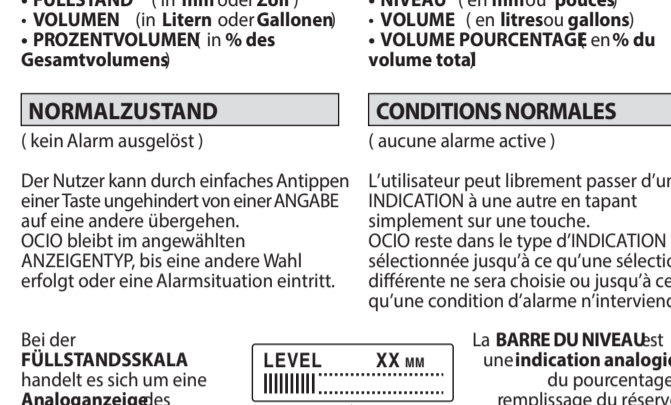

Visualisation du SERIAL NUMBER

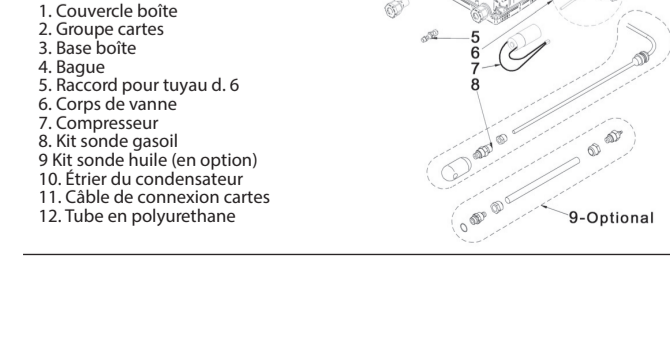
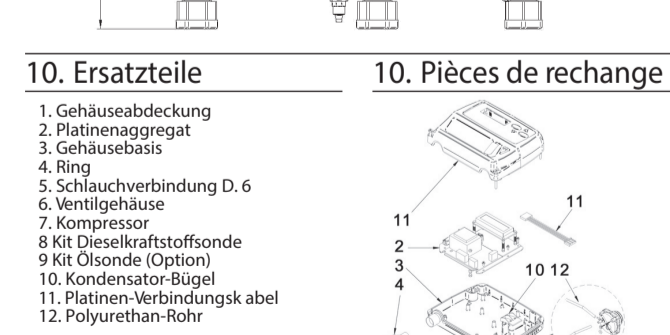
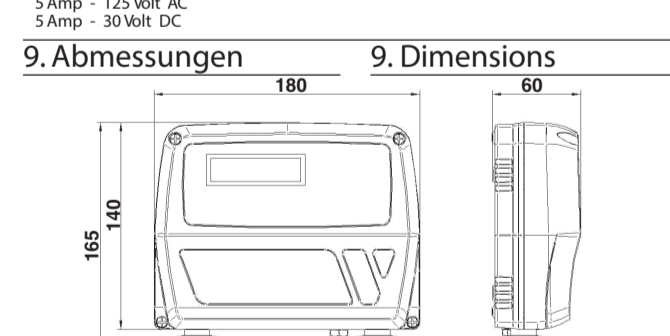
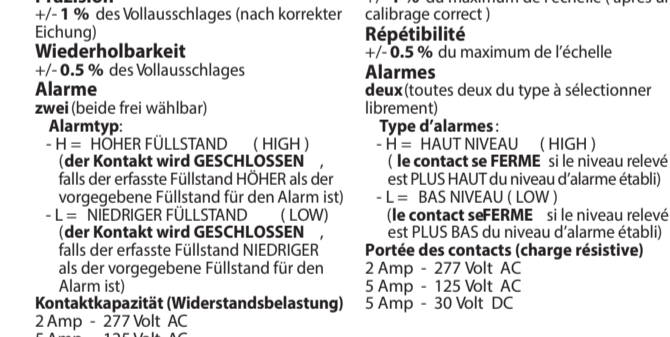
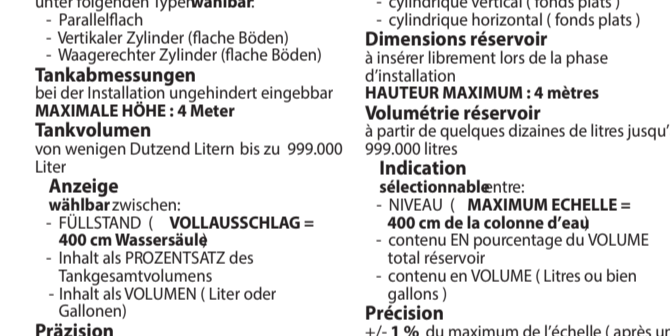
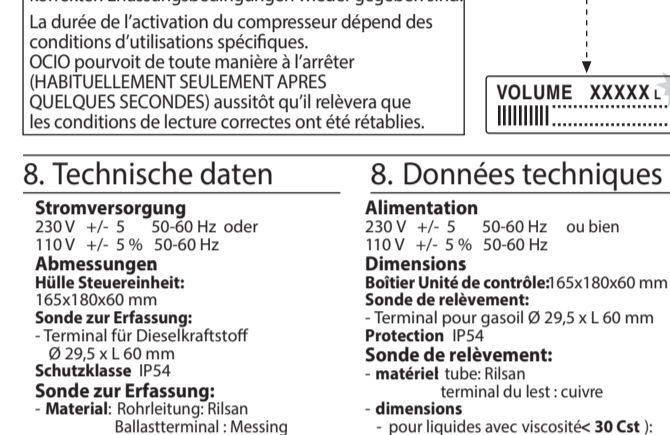
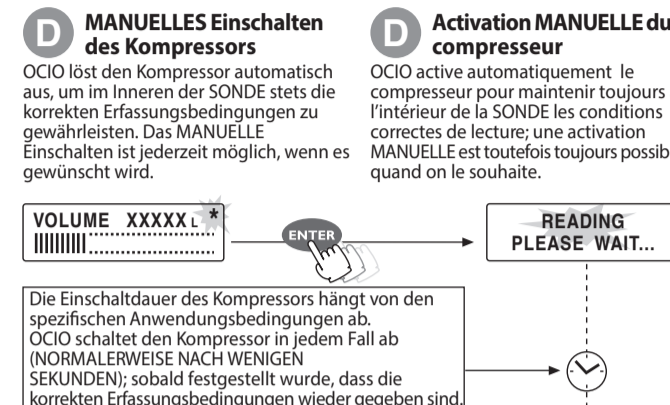
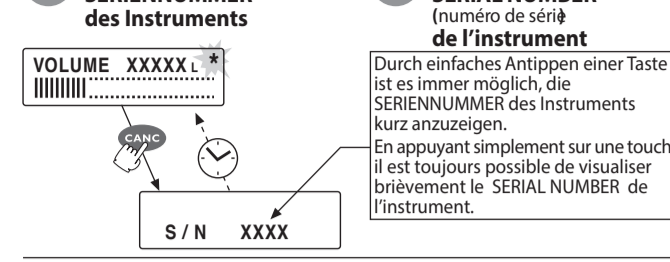

OCIO SYSTEME DE GESTION DU NIVEAU DU RESERVOIR



Table with 2 columns: INHALTSVERZEICHNIS and TABLE DES MATIERES. Lists contents of the manual.

MADE IN ITALY
Manuel d'installation et d'utilisation
Installations- und Betriebsanleitung

BULLETIN MO073 F FRDE .OO
PIUSI S.p.A. Via Pacinotti 16/A z. Rangovino - 46029 Suzzara - Mantova - Italy

11. Copie similaire de la déclaration UE de conformité
11. Faksimile kopie der Erklärung EU-Konformität

La société soussignée: PIUSI S.p.A.
DECLARE sous sa responsabilité que l'équipement décrit ci-après...

Die unterzeichnende Firma: PIUSI S.p.A.
ERKLÄRT in eigener Verantwortung, dass das nachfolgend beschriebene Ausrüstung...

10. Ersatzteile / 10. Pièces de rechange
List of spare parts for the OCIO device.

